

Key Features:

- » 6.5" Coaxial Driver, High Efficiency
- » Compact size
- » Sleek, premium, minimalist appearance to fit nearly any Decor
- » 16 Ohm OR 70V/100V operation
- » Integrated mounting hardware

Applications:

- » Restaurants and Hospitality
- » Educational Facilities
- » Clubs, Lounges, Bars
- » Performing Arts Centers

The iC6T is a premium low profile, high efficiency, high output, coaxial ceiling loudspeaker with a compact form factor. This highly versatile device provides consistent coverage and full frequency sound to a wide range of commercial environments that require higher sound pressure levels and higher fidelity, from hotels and concourses to retail outlets, bars and restaurants. These combined properties deliver the characteristic RMS-Acoustics sonic qualities of Impact, precision, and musicality.

The iC6T features a 6.4" (162mm) low frequency driver paired with a 0.8" (20mm) metal dome tweeter. It is suitable for both high quality speech and music reproduction. A conical 105° coverage pattern delivers consistent, high performance sound where it needs to go. Each individual iC6T can have an independently selected 70 or 100 Volt tap, or wired in parallel at 16 ohm impedance. The 16 ohm setting allows up to 6 units to be connected to each RMS-Acoustics DSP controlled amplifier channel at low impedance. Tap selection is via a rotary switch behind the removable grille.

An integral mounting system is included, to achieve a simple and clean installation. The iC6T has a steel back can, perforated steel grill and is finished in a neutral, medium white color.

Proprietary DSP processing and protection algorithms are implemented in the RMS-Acoustics RMS-425Ki amplifier. The RMS-ACOUSTICS series of processed amplifiers are the recommended amplification solution for the iC6T. Additionally, the Linea Research C and M series amplifiers, with proprietary presets provided by RMS-ACOUSTICS are supported.



System Specifications:

SYSTEM:			
Frequency Range (-10dB) ^1	100Hz - 19kHz		
Frequency Response (+/-3dB)	115 Hz - 18kHz		
System Sensitivity (1w, 1m)^2	90dB	Measured on LF band, average SPL over 80 to 400 Hz region. HF Sensitivity significantly higher	
Maximum SPL Continuous (1m)	108dB		
Maximum SPL Peak (1m)	111dB		
TAPS 70V, TAPS 100V	FR	60, 30, 15, 7.5 W	60,30,15W
Long Term Power Rating (AES)^4	FR	60W (120W Peak), 2 hrs, 50W 100Hr	
Maximum Input Voltage	FR	32 V RMS (2 hrs), 64V Peak	
Nominal Coverage Pattern	110° conical		
System Crossover	Proprietary DSP via RMS-ACOUSTICS processing platform HPF filter 100 Hz		
Loudspeaker	SPKR-6-0008	LF Driver - 6.4" low frequency cone loudspeaker with coaxial 0.8" dome tweeter	
Impedance	LF	16 Ohm, OR 70V/100V speakers internally wired through xover and parallel to 1+ 1-	
PHYSICAL:			
Input Connectors	Phoenix Connector, 4 Pin Euroblock 5.08mm pitch with link out		
Enclosure Materials	Zinc Plated Steel		
Grille Materials	Powder Coated Steel with cloth backing		
Finishes	White, Paintable, additional custom spray finishes available (Upcharge)		
Suspension and Mounting	Proprietary internal, captive rigging		
Fire Rating	UL94-V0		
Included Accessories	2 tile support rails (for 2 ft or 600 mm tile spans) cutout template paint shield removable locking multi-pin connector		
Dimensions	9.88" w x 9.88" d x 8.08" h (251mm x 251mm x 206mm) 7.63" h (194mm) Flush to rear		
Weight	6.6Lbs (3 kg) Net	Shipping weight 16Lb 7.3 kg 2 pack	
Finish Options	-W (White), -C (Custom Color) Upcharges apply		
Recommended Subwoofer	SB208i		

Wall mounted, semi anechoic conditions.

1. Half Space, 2pi conditions

2. Measured Maximum SPL, based on power compression observation of 3dB

3. IEC Shaped pink noise with 6dB Crest Factor

4. AES Standard AES2-2012, one decade pink noise with 6dB Crest factor within device's applicable operating band, free air. Standard AES 2 hr rating are specific for low frequency transducers.

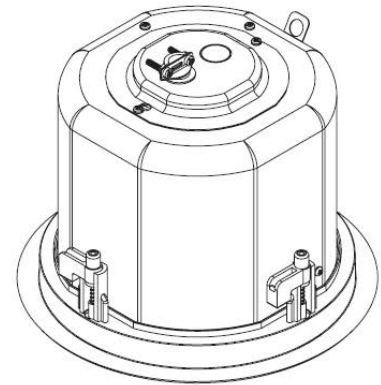
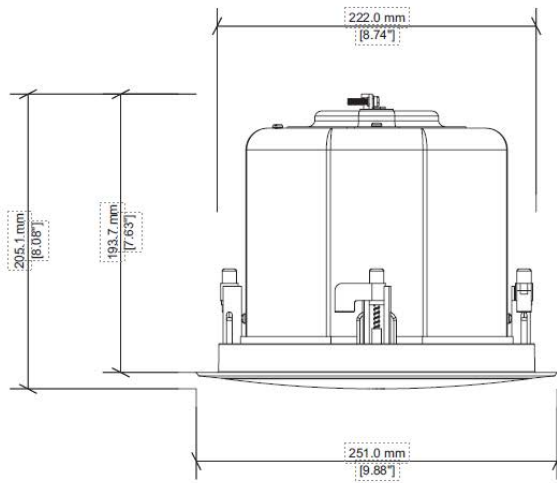
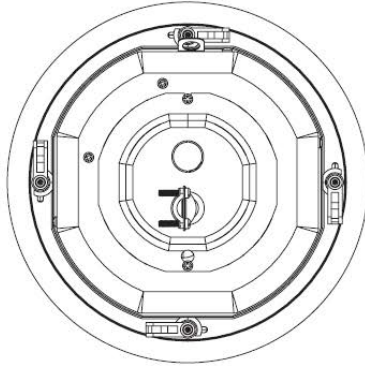

Connection Diagram 2-way, Single-Amp

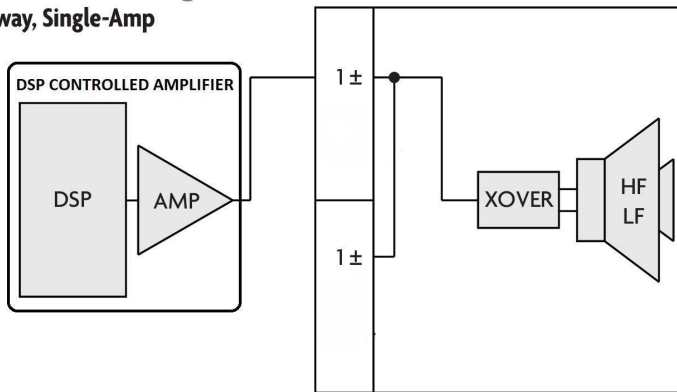

Architectural Specification

The loudspeaker shall be comprised of one coaxial 6.4" (162mm) (LF) X 0.8" (20mm) (HF) transducers. The transducer shall be mounted in a rectangular zinc plated steel enclosure with front baffle constructed of high temperature ABS. The enclosure topology shall be a vented bandpass featuring laminar venting. This loudspeaker system shall have an internal passive crossover, transformer with both 70V and 100V power taps, and ceiling mounting hardware; it shall be finished in a neutral white coating with exterior dimensions of (H) 251 mm x (W) 251 mm x (D) 194mm (9.88" x 9.88" x 7.63") and weigh 3 kg (6.6 lbs).

The wiring connection shall be as follows: a removable, lockable wiring connector with four screw-down terminals (one pair for input and one pair for link through to another loudspeaker) to provide secure wiring and allow for pre-wiring of the connector before the installation (this connector should then lock to the enclosure for secure attachment).

Performance specifications of a typical production unit shall be as follows: frequency response of 115 Hz – 18kHz (± 3 dB from rated sensitivity); 60 W long-term program using IEC268-5 pink noise (6 dB crest factor); pressure sensitivity of 90 dB one Watt one meter; rated nominal impedance of 16 Ω with optional 70V and 100V power taps.

The loudspeaker system shall be the **RMS-Acoustics iC6T**.